

# Using SPARK as a Solver for Modelica

Michael Wetter

Philip Haves

Michael A. Moshier

Edward F. Sowell

July 30, 2008



# Overview

- Overview of SPARK, Modelica, OpenModelica, Dymola
- Problem reduction
- SPARK integration in OpenModelica
- SPARK/Dymola benchmark
- Future work

SPARK, Modelica, OpenModelica, Dymola

# Modelica

- Modeling language developed since 1996 by Modelica Association
  - Model development environments
  - Solvers
- Designed by developers of
  - Allan, Dymola, NMF, ObjectMath, Omola, SIDOPS+, Smile
- Well positioned to become de-facto standard for modeling multi-engineering systems
  - e.g.: ITEA2 (Euroslib: 110 man years, 20 partners to develop Modelica libraries, but not for building HVAC systems).
- Supports differential, algebraic and discrete equations
- Declarative instead of imperative
- Object-oriented
- Automatic documentation

# SPARK

- Developed since 1989 by LBNL and Ayres Sowell Associates
- Supports differential and algebraic equations
- Declarative instead of imperative
- Uses graph-theoretic methods to:
  - define well-posed problems
  - generate computationally efficient solution sequences

# Overview

	Language	Modeling Environment	Translator, code generator, simulator
SPARK			
Modelica			
OpenModelica			
OpenModelica/SPARK			
Dymola			

The diagram illustrates the relationships between the tools listed in the table. A vertical line in the Language column has three arrows pointing to the rows for OpenModelica, OpenModelica/SPARK, and Dymola. A vertical line in the Translator, code generator, simulator column has one arrow pointing to the row for OpenModelica/SPARK. A vertical line in the Modeling Environment column has one arrow pointing to the row for OpenModelica/SPARK.

## Questions:

- 1) How can SPARK be used as a solver for OpenModelica?
- 2) How does SPARK compare with best in class Modelica simulator?

# Dymola/SPARK Comparison

## Features and availability

	Dymola	SPARK
Partitioning		
Tearing		
Inline-integration		
Index reduction		
Automatic differentiation		
Availability	\$1-10k	Executable free (kernel is not open-source)

# Partitioning or Component Reduction

1:  $Q = T_1 - T_2$

2:  $0 = T_1$

3:  $f(t) = T_1 + T_2$

	$T_1$	$T_2$	$Q$
1	shaded	shaded	shaded
2	shaded	white	white
3	shaded	shaded	white

	$T_1$	$T_2$	$Q$
2	shaded	white	white
3	shaded	shaded	white
1	shaded	shaded	shaded

Application  
to an electric  
circuit model

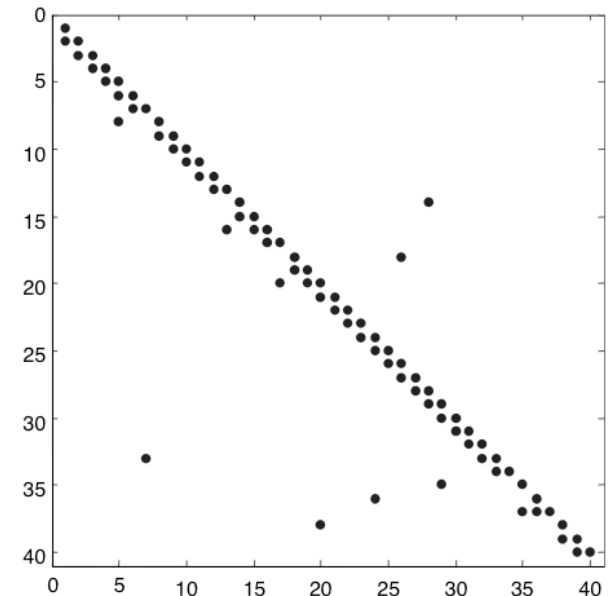
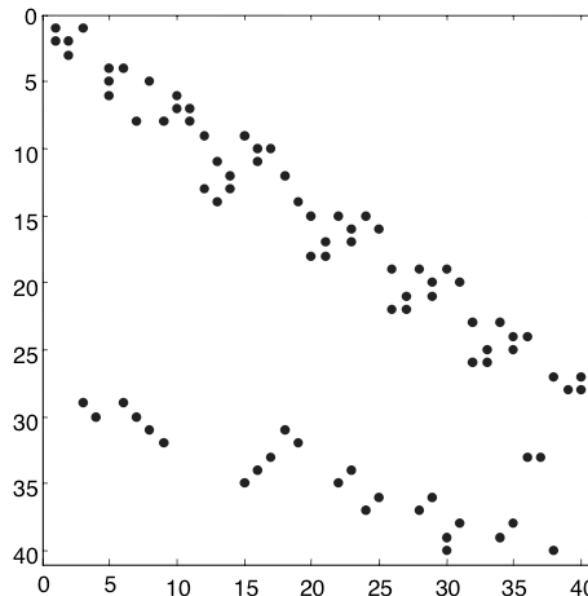

Bunus and Fritzson (2004)

# Tearing or Cut-Set Reduction

Suppose we have an equation

$$0 = f(x), \quad x \in \mathfrak{R}^n, \quad n > 1,$$

that can be written in the form

$$(1) \quad L x^1 = \hat{f}^1(x^2),$$

$$(2) \quad 0 = \hat{f}^2(x^1, x^2),$$

where  $L$  is a lower triangular matrix with constant non-zero diagonals.

Now, pick a guess value for  $x^2$ , solve (1) for  $x^1$ , and compute a new value for  $x^2$  from (2).

Iterate until  $x^2$  converges to a solution.

# SPARK/OpenModelica Integration

# SPARK Integration

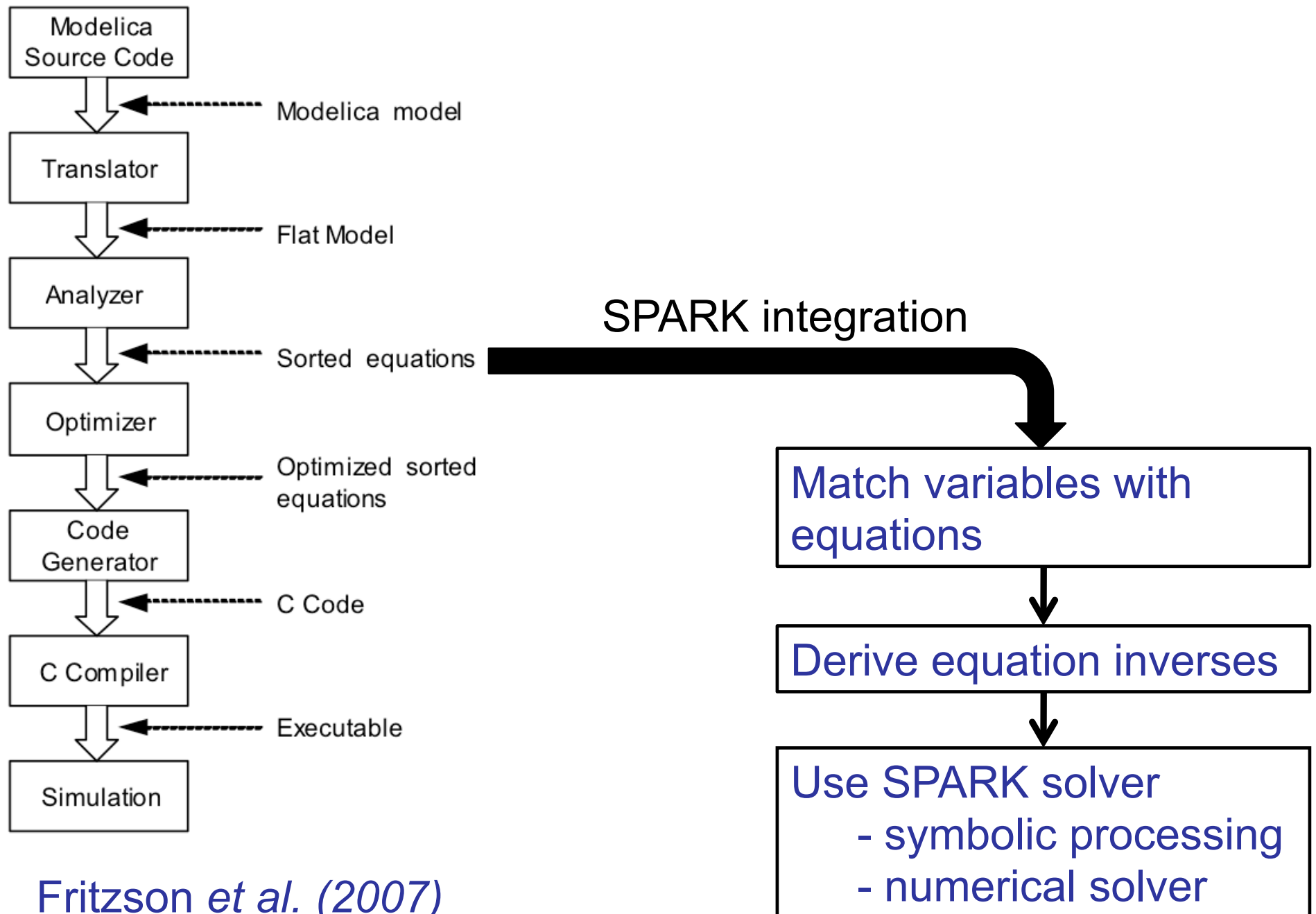

# Integration

- Modify the open source Modelica compiler to
  - Construct **internal data structures** corresponding to SPARK classes (individual equations and sub-systems)
  - Generate **SPARK class definitions**
  - Use another open source system (e.g., SAGE) to perform needed **algebraic manipulations**
- Use **Modelica annotations** (part of the Modelica standard) to give user access to SPARK controls
- Modify SPARK API to integrate **diagnostics** into OpenModelica (future work)
- Build **algorithmic** code generator (near future work)

# Current Status

- Compiler now **emits basic version** of SPARK model
  - No user control via annotation
  - Does not provide code for re-use
- **Compiler supports data structures** corresponding to SPARK classes (sub-models) including user controls.
- Need to build code generator for the latter (straightforward task)

# Dymola/SPARK Benchmarking

# Dymola/SPARK Benchmarking

Test problem:

- Airflow network (pressure & mass flow rate only)
- Algebraic system of equations
- Scaled VAV air distribution system (ASHRAE 825-RP)

# Dymola/SPARK Benchmarking

Schematic view of VAV System described in ASHRAE 825-RP

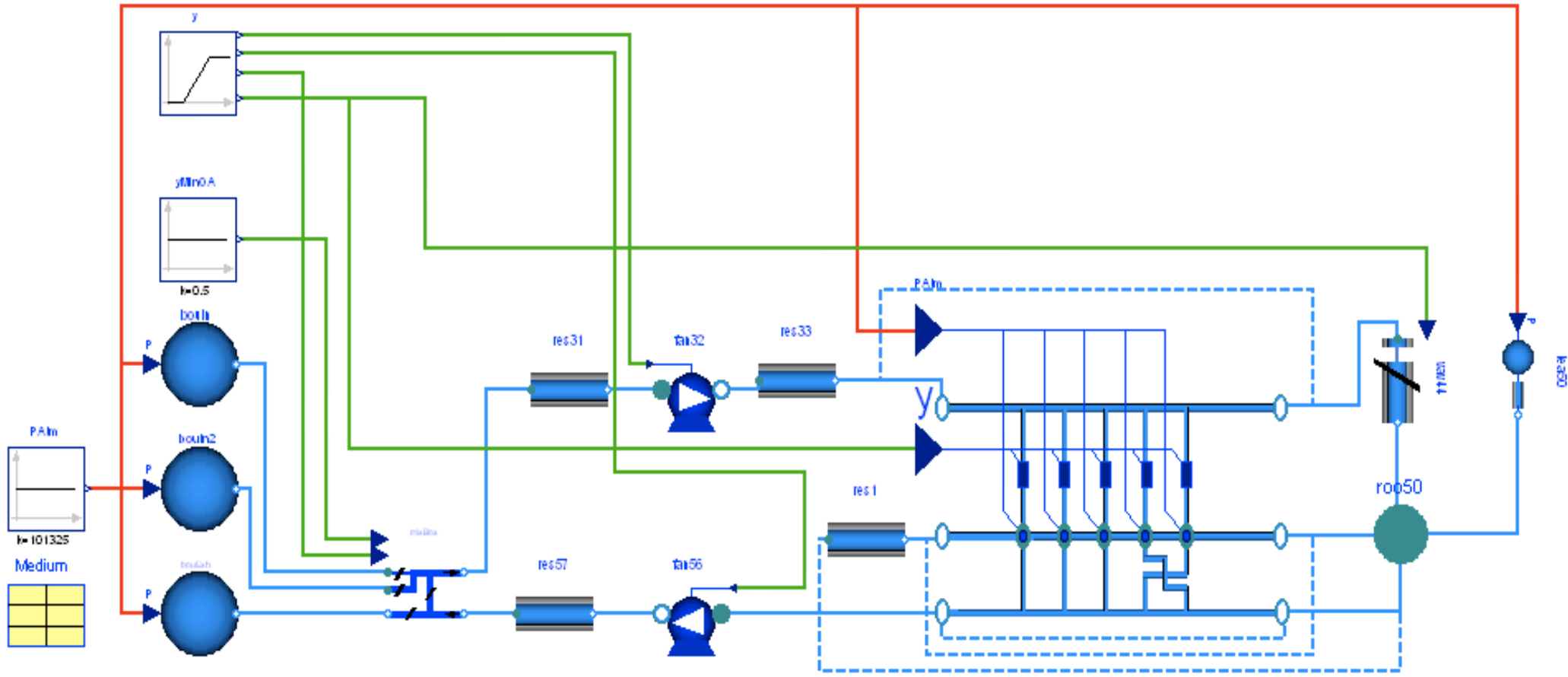

# Dymola/SPARK Benchmarking

yOutMin

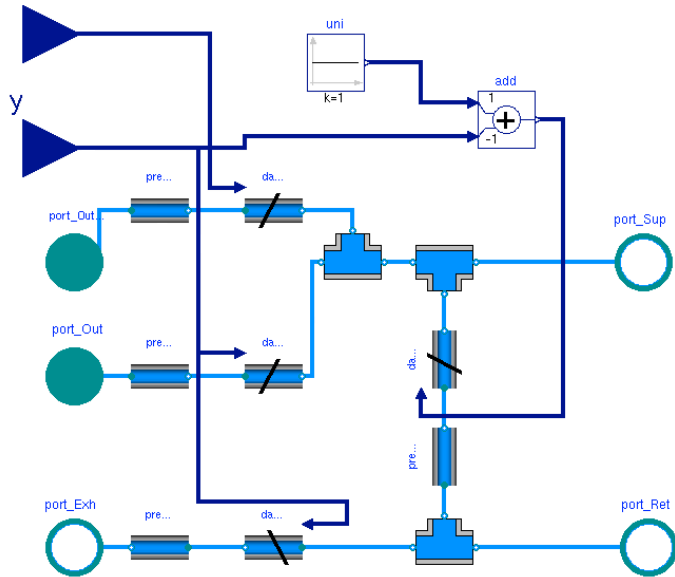

**Packages**

- FixedResistanc...
- FlowMachinePo...
- OAMixingBoxMi...
- PrescribedSource
- SimulationTime
- Splitter**
- SplitterFixedResis
- Tests
- VAVBoxExponent
- Volume

**Components**

- FlowNetwork.Compo...
- port\_1
- port\_2

Splitter - FlowNetwork.Components.Splitter - [Modelica Text]

lot Animation Commands Window Help

```
model Splitter
  "Splitting/joining component with static
  balances for an infinitesimal control volume"

  FlowNetwork.Interfaces.FluidPort_b port_1 #;
  FlowNetwork.Interfaces.FluidPort_b port_2 #;
  FlowNetwork.Interfaces.FluidPort_b port_3 #;

  Modelica.SIunits.AbsolutePressure p(nominal=1E5) "Pressure";
  #;
equation
  port_1.m_flow + port_2.m_flow + port_3.m_flow = 0 "Mass balance";

  // Momentum balances
  port_1.p = p;
  port_2.p = p;
  port_3.p = p;
end Splitter;
```

Line: 3 Modeling Simulation

# Dymola/SPARK Benchmarking

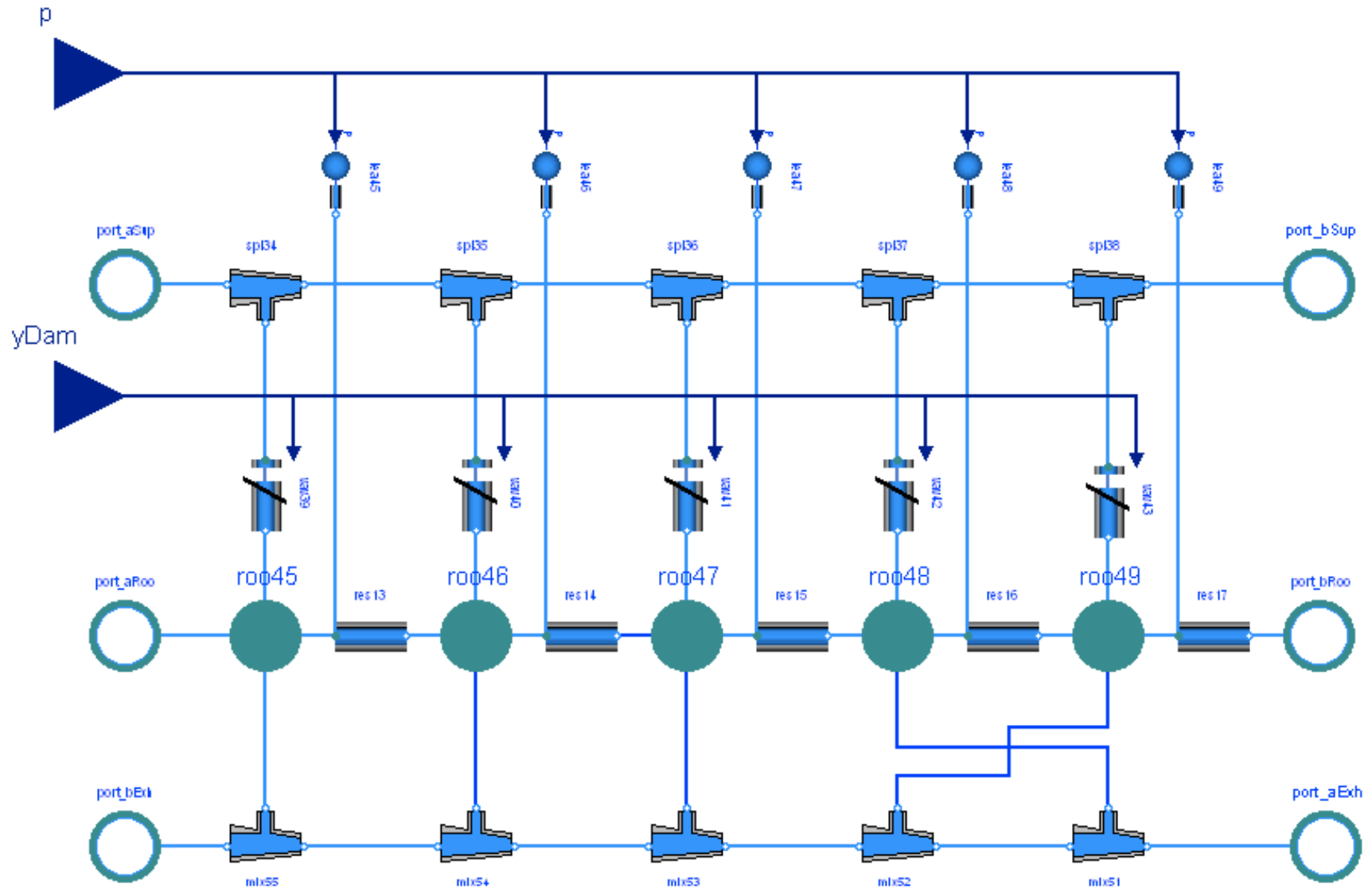

# Dymola/SPARK Benchmarking

## Symbolic processor

## Numerical performance

Table 1: Dimension of biggest nonlinear system of equations. For the SPARK, no ML denotes no MATCH\_LEVEL and with ML denotes with MATCH\_LEVEL.

$N_{sui}$	SPARK		Dymola	
	no ML	with ML	$\dot{m} = f(\Delta p)$	$\Delta p = g(\dot{m})$
1	21	18	41	26
2	36	34	71	47
3	51	50	101	66
4	66	65	131	87
5	81	80	161	106

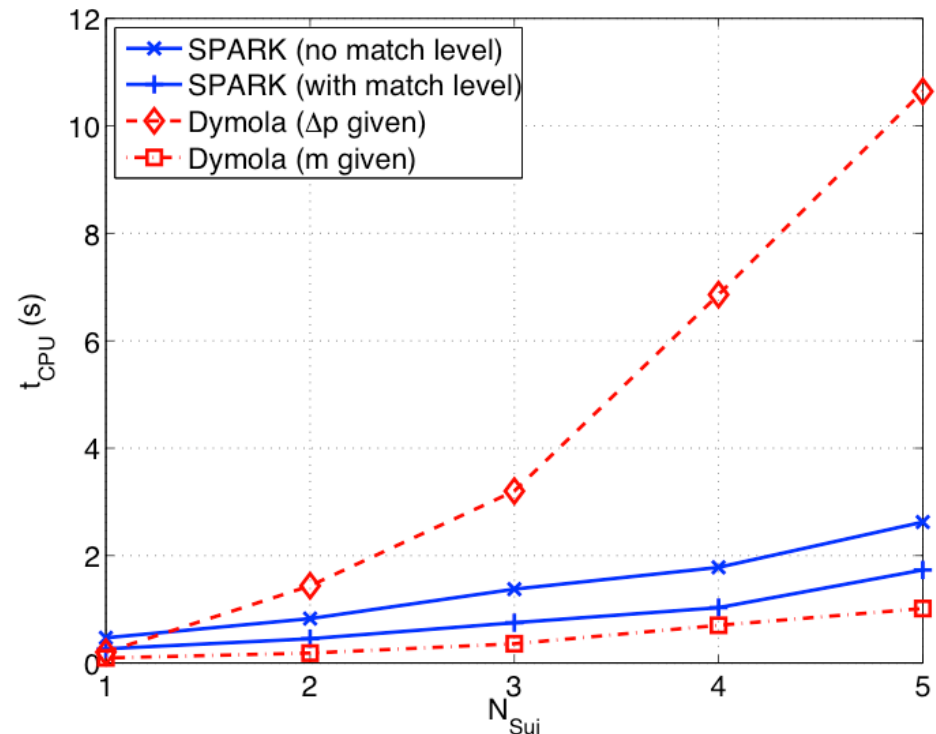

# Summary of Benchmarks

- SPARK is **compatible** with Modelica language
- SPARK has a robust, high performance solver for nonlinear equations, **competitive** with expensive commercial systems
- OpenModelica has provided a **useful testbed** for integrating SPARK

Future work...

# Future Work

**SPARK/OpenModelica:** Continue integration

**Modelica modeling:** Open-source buildings library development

**Modelica co-simulation:** Open source Building Controls Virtual Test Bed development.

Will link Modelica to EnergyPlus.

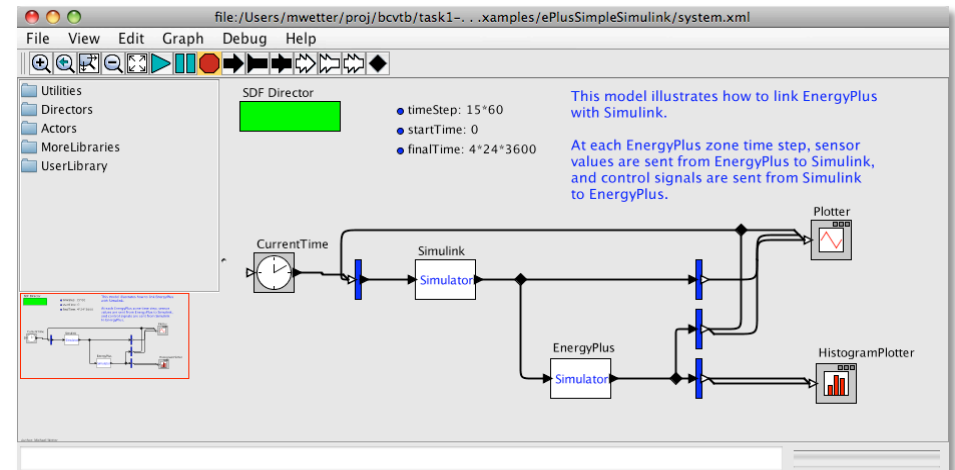
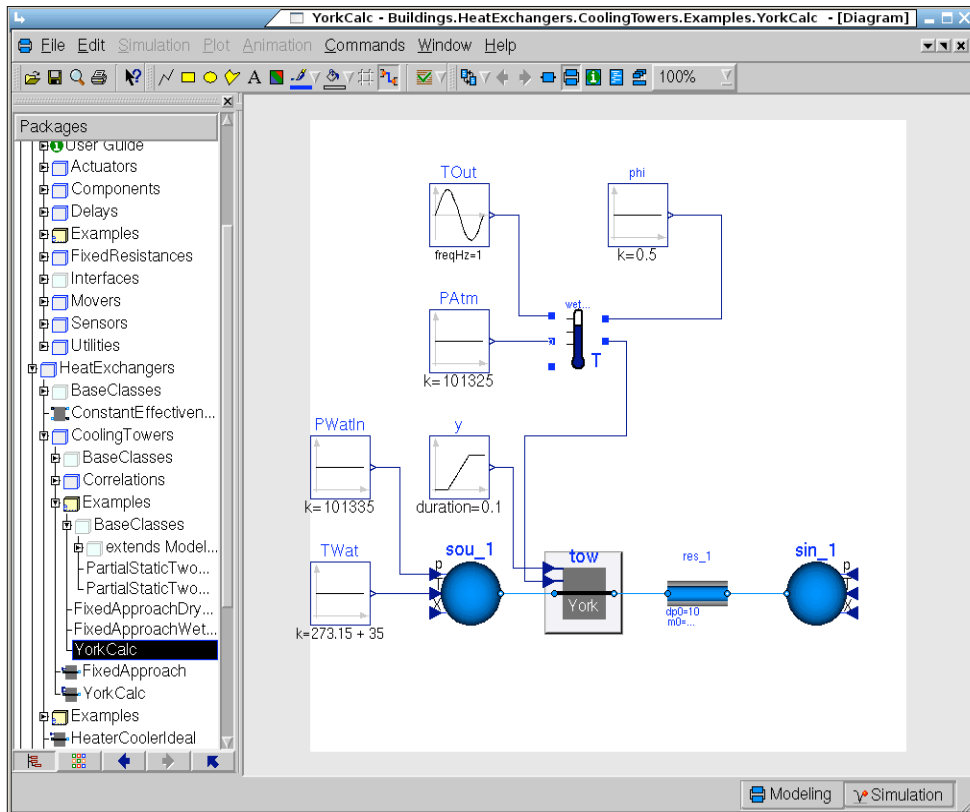

<https://gaia.lbl.gov/bir>

<https://gaia.lbl.gov/bcvtb>