

Simbuild 2008

IBPSA US - 3<sup>rd</sup> National Building Simulation Conference  
Berkeley, CA

*Building and HVAC system simulation with the help of  
an engineering equation solver*

S. Bertagnolio, G.Masy, P.André and J.Lebrun  
stephane.bertagnolio@ulg.ac.be



University of Liège  
Department of Aerospace and Mechanical Engineering  
Thermodynamics Laboratory

---

# Table of Contents

- Introduction
- Building energy simulation tool for Audit
- Modelling Bases
- Validation of the building model
- Implementation in an equation solver and application
- Conclusion

---

# Motivation for this presentation

- Energy simulation useful from **HVAC system design** → **audit and retrofit actions**
  - Simulation tools available according to the available information
  - Tools required to be simple, transparent and easy-to-update
  - **How Equation Solvers can help us to do the job ?**  
(EES, © F-Chart Software)
- Focus on a building energy simulation tool developed for benchmarking and audit

---

# Table of Contents

- Introduction
- **Building energy simulation tool for Audit**
- Modelling Bases
- Validation of the building model
- Implementation in an equation solver and application
- Conclusion

---

# Building energy Simulation for Audit ?

- **Benchmarking**

**Statistics** and arbitrary normalization **not always adapted** for benchmarking due to **large diversity of the building stock**

→ Building energy simulation software

→ “reference” performance

- **Pre – audit**

Available **global data** (energy bills) **insufficient** to analyze the performance of the installation

→ **Calibrated** building energy simulation software

→ **dis-aggregation** of energy consumption

- **Detailed Audit**

Evaluation of Energy Conservation Opportunities

---

# Table of Contents

- Introduction
- Building energy simulation tool for Audit
- **Modelling Bases**
- Validation of the building model
- Implementation in an equation solver and application
- Conclusion

---

# Modelling Bases

- Hourly simulations
- **Simplified models** with limited quantity of parameters according to the **available information**
- Two main parts :
  - **1 Dynamic Building model** adjusted with geometrical data, walls characteristics, orientations,...
  - **1 Static HVAC system model** including Air Handling Unit, Terminal Units, Distribution networks and Heat/Cool production systems

# Inputs / Outputs / Parameters

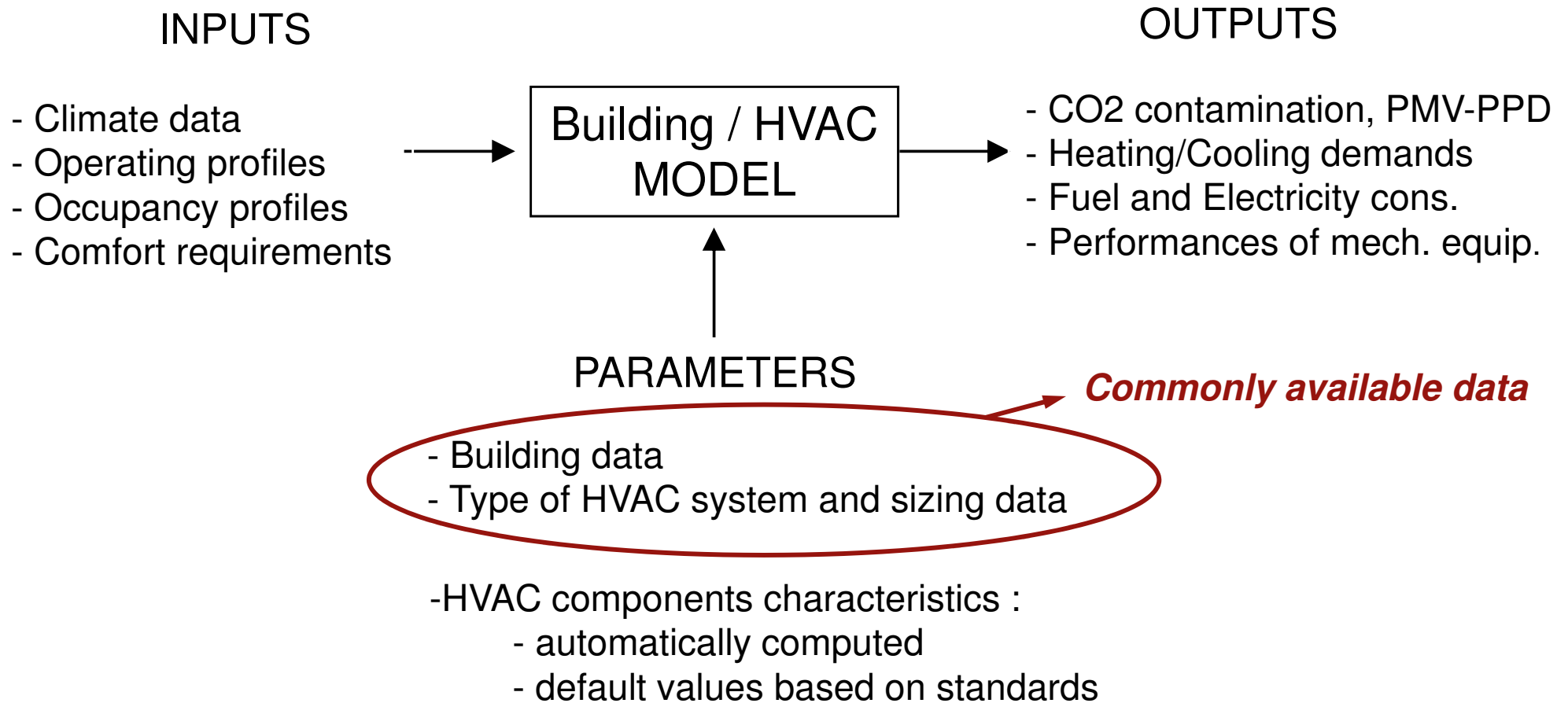

# Building zone model

- Lumped RC model developed by Laret (1981)
  - Only 2R1C branches to keep limited quantity of parameters
  - Equation solver well adapted to solve differential equations
- Influences
  - Envelope dynamic behavior
  - Structure dynamic behavior
  - Solar gains
  - Long-wave radiation losses
  - Ventilation and Infiltration
  - Internal gains

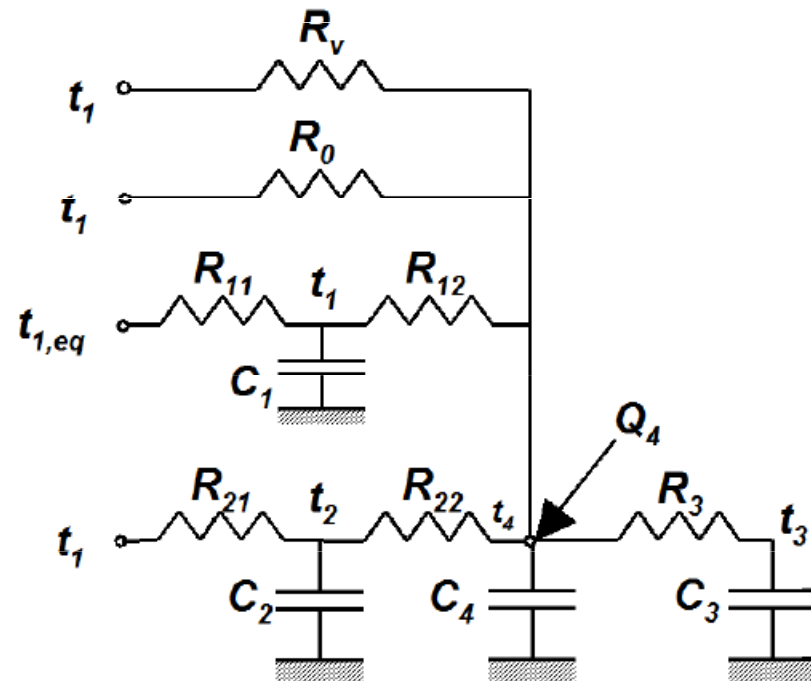

# Tuning of the building zone model

- Two types of boundary conditions
  - Isothermal** (external walls, in contact with outdoor “cold” zones) : 2R1C

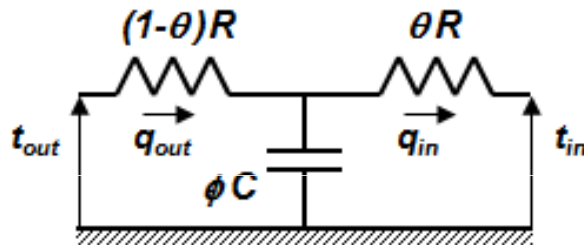

- Adiabatic** (internal walls, between similar zones) : 3R2C

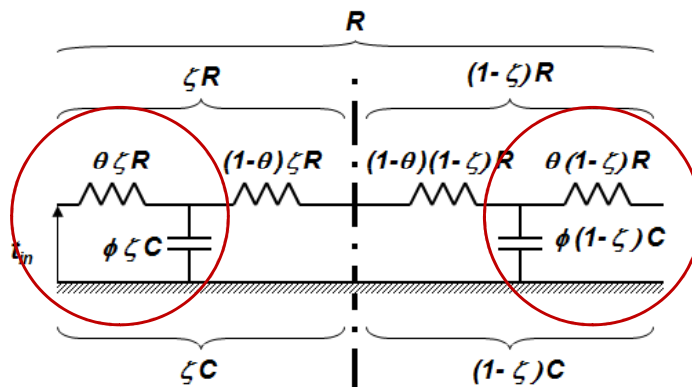

Null heat flow plane

→ Walls parameters to compute : R, C, θ, φ and ζ

Null heat flow plane :

$$f_d = \prod_{i=1}^n \exp\left(-d_i \cdot \sqrt{\frac{\omega}{2\alpha_i}}\right) \rightarrow \zeta$$

# Wall parameters calculation

- Frequency characteristic analysis for a 24h period sinusoidal solicitation
- Temperature and heat flow variations (complex quantities) are correlated by :

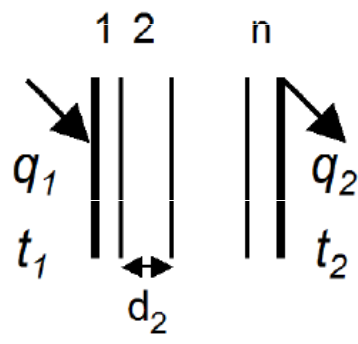

$$\begin{pmatrix} \tilde{t}_1 \\ \tilde{q}_1 \end{pmatrix} = \begin{pmatrix} A_1 & B_1 \\ C_1 & D_1 \end{pmatrix} \begin{pmatrix} A_2 & B_2 \\ C_2 & D_2 \end{pmatrix} \cdots \begin{pmatrix} A_n & B_n \\ C_n & D_n \end{pmatrix} \begin{pmatrix} \tilde{t}_2 \\ \tilde{q}_2 \end{pmatrix}$$

*Complex quantities (function of the material characteristics)*

- Wall reverse transfer matrix Q : 
$$\begin{pmatrix} \tilde{t}_1 \\ \tilde{q}_1 \end{pmatrix} = \begin{pmatrix} Q_{11} & Q_{12} \\ Q_{21} & Q_{22} \end{pmatrix} \begin{pmatrix} \tilde{t}_2 \\ \tilde{q}_2 \end{pmatrix}$$

# Wall parameters calculation

- **Isothermal conditions** : modulus of admittance  $|A_v|$  and transmittance  $|K_v|$  are imposed to the 2R1C model

$$|\tilde{A}_v| = \left| -\frac{Q_{11}}{Q_{12}} \right| \quad |\tilde{K}_v| = \left| \frac{1}{Q_{12}} \right|$$

$$\rightarrow \theta = \frac{\sqrt{U^2 - |\tilde{K}_v|^2}}{\sqrt{|\tilde{A}_v|^2 - |\tilde{K}_v|^2}} \quad \phi = \frac{1}{(1-\theta)\omega RC} \sqrt{\frac{|\tilde{A}_v|^2}{|\tilde{K}_v|^2} - 1}$$

- **Adiabatic conditions** : modulus and phase lag of admittance are imposed to the 2R1C model

$$\tilde{A}_v = -\frac{Q_{21}}{Q_{22}} \rightarrow \theta = \frac{|\Re(\tilde{A}_v)|}{R|\tilde{A}_v|^2} \quad \phi = \frac{|\tilde{A}_v|^2}{\omega C |\Im(\tilde{A}_v)|}$$

- Each wall described by :  $\boxed{R=1/U}$ , in  $W/m^2K$ ,  $\boxed{C}$  in  $J/m^2K$ ,  $\boxed{\theta}$  and  $\boxed{\phi}$

# Building zone parameters calculation

- **RC network aggregation** : Walls admittances and transmittances multiplied by wall areas and summed for each wall category
    - 3 admittance matrixes = 3 branches for each building zone:
      - roof slabs
      - external walls
      - internal walls : floor slabs, partition walls
- Light and simplified RC network model with limited quantity of parameters

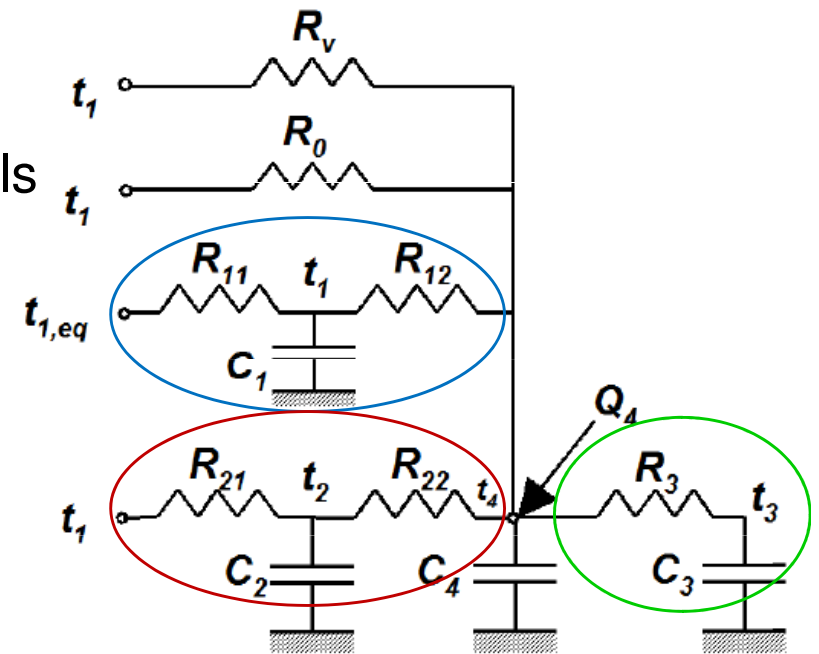

# Building zone parameters calculation

- Adjustment parameters  $\theta$  and  $\varphi$  stay in a limited range for frequent walls compositions
  - **walls library** with standard values available for the user
  - Definition of **walls categories** characterized by similar values of the parameters  $\theta$ ,  $\varphi$  and  $\zeta$

*A : massive wall, strongly ventilated air layer or outdoor insulation*

*B : massive insulated walls*

*C : massive wooden structure*

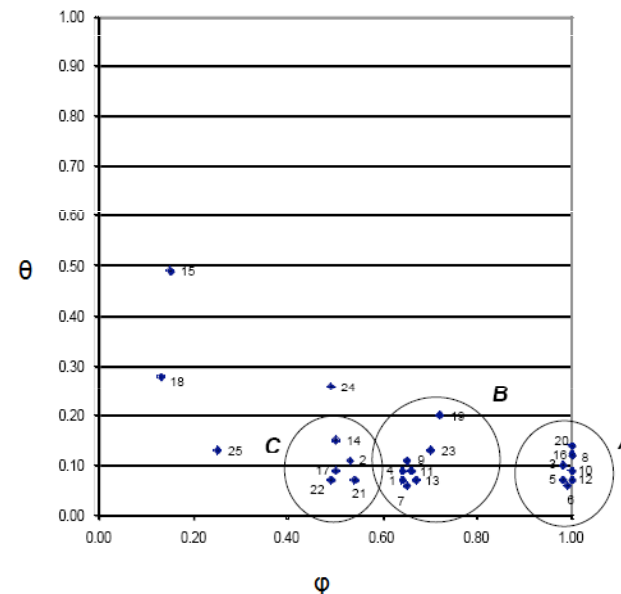

Standard values can be used without important loss of accuracy but simplifies greatly the parametrization work for the user (Masy's PhD thesis)

---

# Table of Contents

- Introduction
- Building energy simulation tool for Audit
- Modelling Bases
- **Validation of the building model**
- Implementation in an equation solver and application
- Conclusion

# Building model Validation

- Empirical validation (IEA ECBCS Annex 43)
  - *Measured heating power is imposed to the model*
  - *Measured and computed indoor temperature are compared*

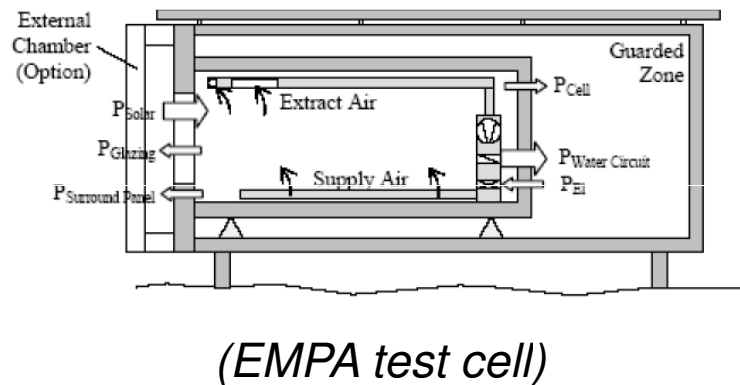

*Error RMS : 0.46 K*

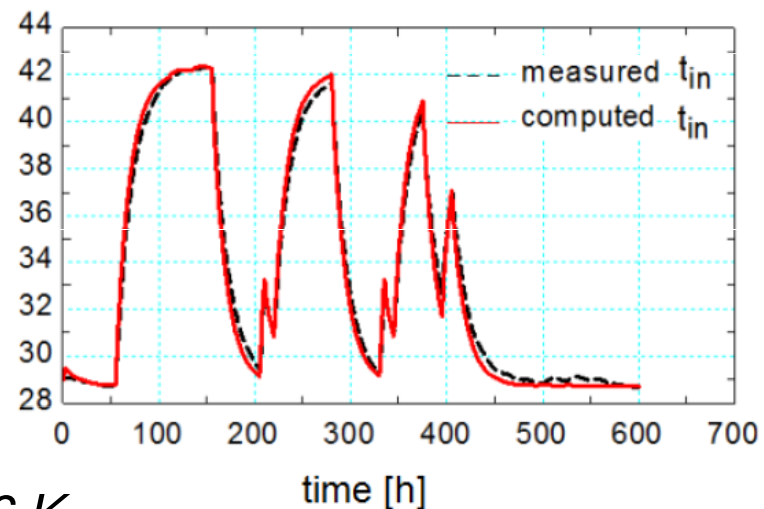

- Analytical validation (response factors convolution process) (Masy, 2008)

*Max Error RMS : 0.6 K*

# Building model Validation

- Comparative validation (IEA BESTEST)

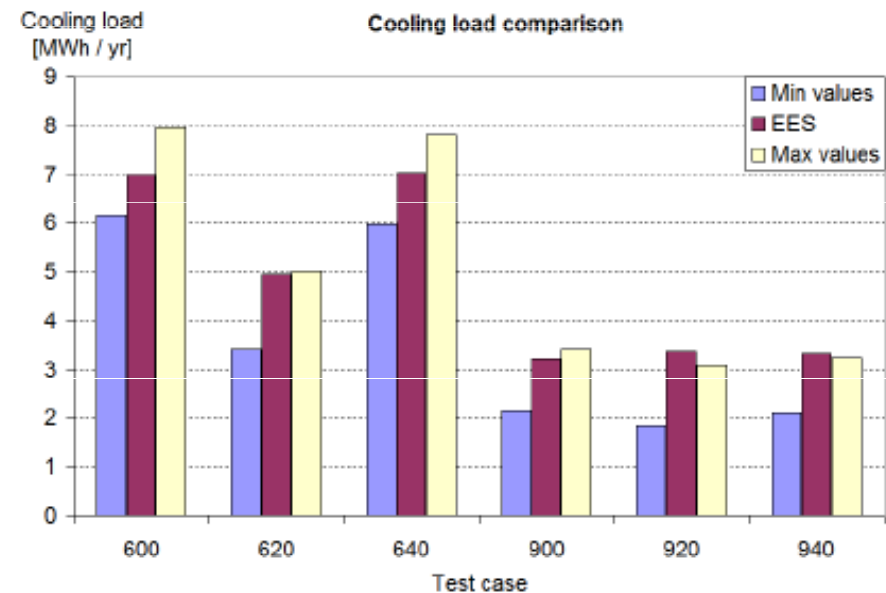
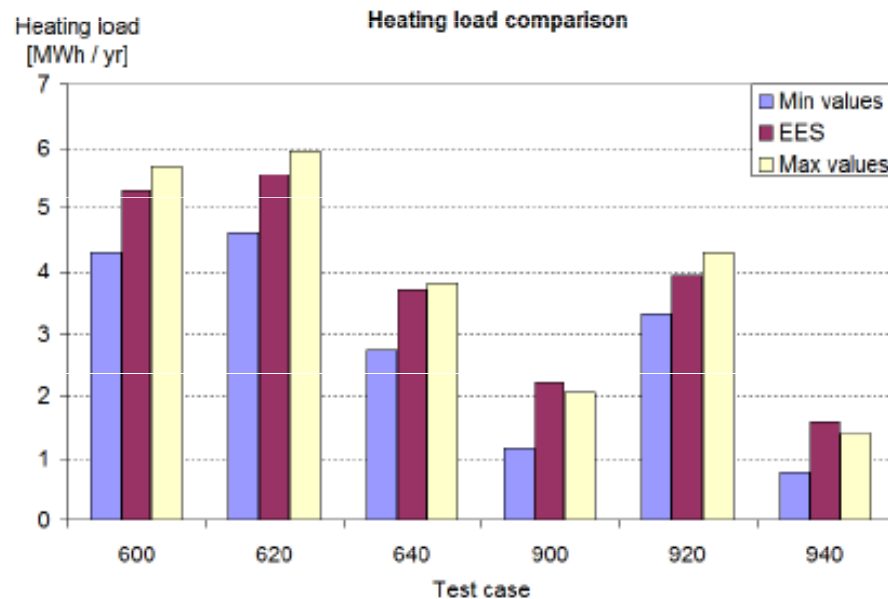

*Good results for lightweight cases*  
*Discrepancies for heavyweight cases*

# Building model Validation

- Comparative validation (IEA BESTEST)

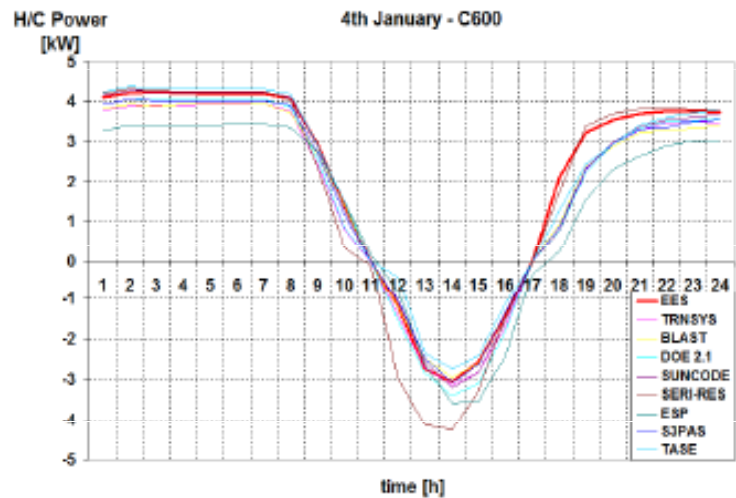

*(lightweight)*

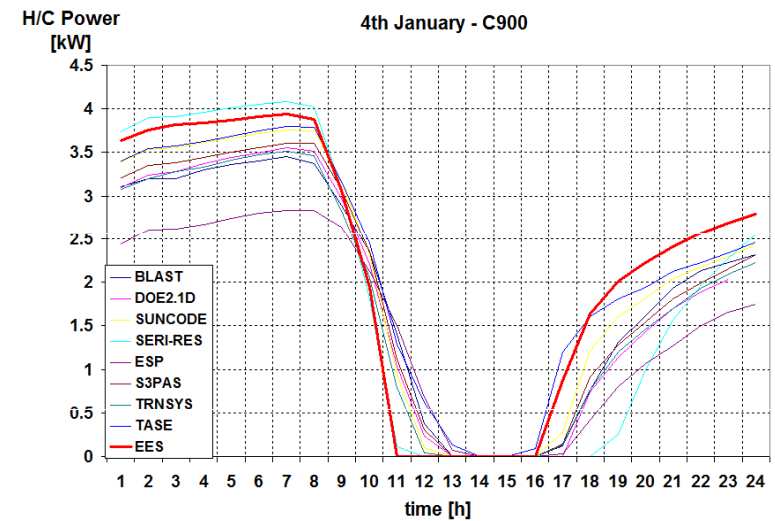

*(heavyweight)*

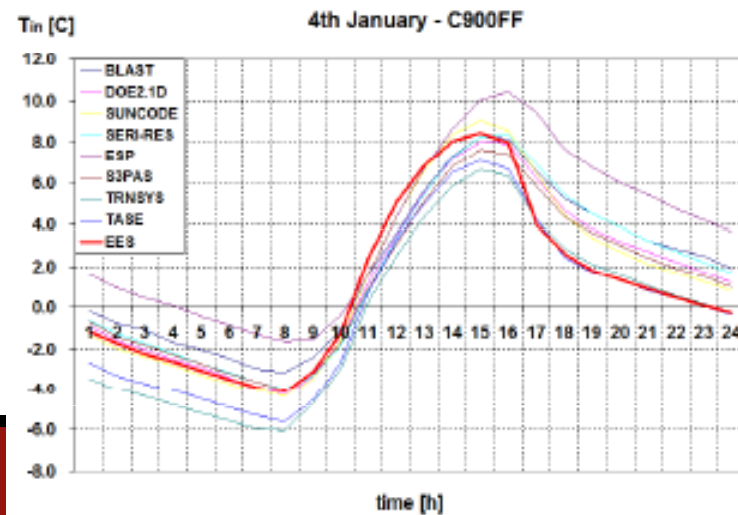

*(heavyweight, floating temp.)*

---

# Building model Validation

- Simplified dynamic building model
    - Empirical validation : good
    - Analytical validation : good (see Masy, 2008)
    - Comparative validation : quite good
  - Discrepancies :
    - Due to low order of the RC network (problems with heavy outdoor insulated walls)
    - Due to imperfect control (proportional only) of the H/C system
- Sufficient accuracy to be implemented in a simplified building/HVAC simulation tool

---

# Table of Contents

- Introduction
- Building energy simulation tool for Audit
- Modelling Bases
- Validation of the building model
- **Implementation in an equation solver and application**
- Conclusion

# Implementation in an equation solver

- Wall model : 1<sup>st</sup> order differential equation

$$\frac{dU}{d\tau_{wall}} = \dot{Q}_{in} + \dot{Q}_{out}$$

$$\dot{Q}_{out} = \frac{t_{out} - t_{wall}}{(1 - \theta) R}$$

$$\dot{Q}_{in} = \frac{t_{wall} - t_{in}}{\theta R}$$

$$\Delta U_{wall} = \int_{\tau_1}^{\tau_2} \frac{dU}{d\tau_{wall}} d\tau$$

$$\Delta U_{wall} = C (t_{c,wall} - t_{c,wall,1})$$

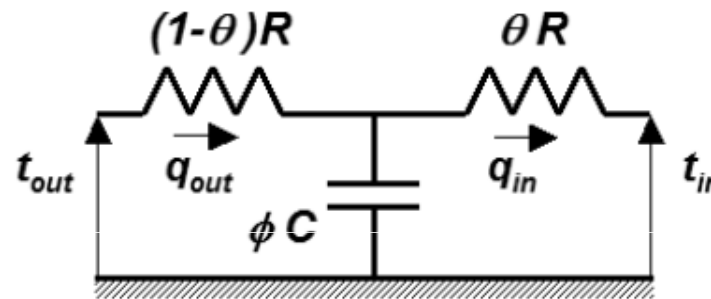

Implementation

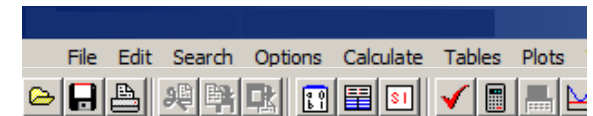

## 2R1C - Wall Model

$$\frac{dU}{d\tau_{wall}} = \dot{Q}_{in} + \dot{Q}_{out}$$

$$\dot{Q}_{out} = \frac{t_{out} - t_c}{(1 - \theta) \cdot R}$$

$$\dot{Q}_{in} = \frac{t_c - t_{a,in}}{\theta \cdot R}$$

$$\Delta U_{wall} = \int_{\tau_2}^{\Delta\tau} \left[ \frac{dU}{d\tau_{wall}} \right] d\tau_1$$

$$\Delta U_{wall} = C_{wall} \cdot (t_c - t_{c,1})$$

# Building Zone Model

- **Sensible Heat Balance** → combined convective-radiative Temp. :  $T_{a,in,zone}$

$$\frac{dU}{d\tau}_{in} = \underbrace{\dot{Q}_{roof,surf,in} + \dot{Q}_{floor,surf,in} + \dot{Q}_{opaque,frontages,surf,in}}_{\text{Transmission trough walls}} + \underbrace{\dot{Q}_{windows}}_{\text{Ventilation and Infiltration}} + \underbrace{\dot{H}_{s,vent} + \dot{H}_{s,inf}}_{\text{Ventilation and Infiltration}} + \underbrace{\dot{Q}_{s,in}}_{\text{Internal Gains}}$$

- **CO2 Mass Balance** → CO2 contamination :  $X_{CO2,in,zone}$

$$\frac{dM}{d\tau}_{CO2,in} = \underbrace{\dot{M}_{CO2,vent}}_{\text{ventilation}} + \underbrace{\dot{M}_{CO2,inf}}_{\text{infiltration/exfiltration}} + \underbrace{\dot{M}_{CO2,in}}_{\text{internal production}}$$

- **Water Mass Balance** → Indoor humidity ratio:  $W_{in,zone}$

$$\frac{dM}{d\tau}_{w,in} = \underbrace{\dot{M}_{w,vent}}_{\text{ventilation}} + \underbrace{\dot{M}_{w,inf}}_{\text{infiltration/exfiltration}} + \underbrace{\dot{M}_{w,in}}_{\text{internal production}}$$

---

# HVAC System Model

- Dynamic mono-zone building model  $\leftrightarrow$  complete steady-state HVAC system model:
  - Air Handling Unit
  - Heating/Cooling Terminal Units
  - Air and Water distribution networks
  - Plant
- HVAC Components aggregated into “global” components
- HVAC components simplified models derived from reference models (ASHRAE HVAC toolkits 1 and 2)

(See other papers for details about the HVAC system model)

# HVAC System Model

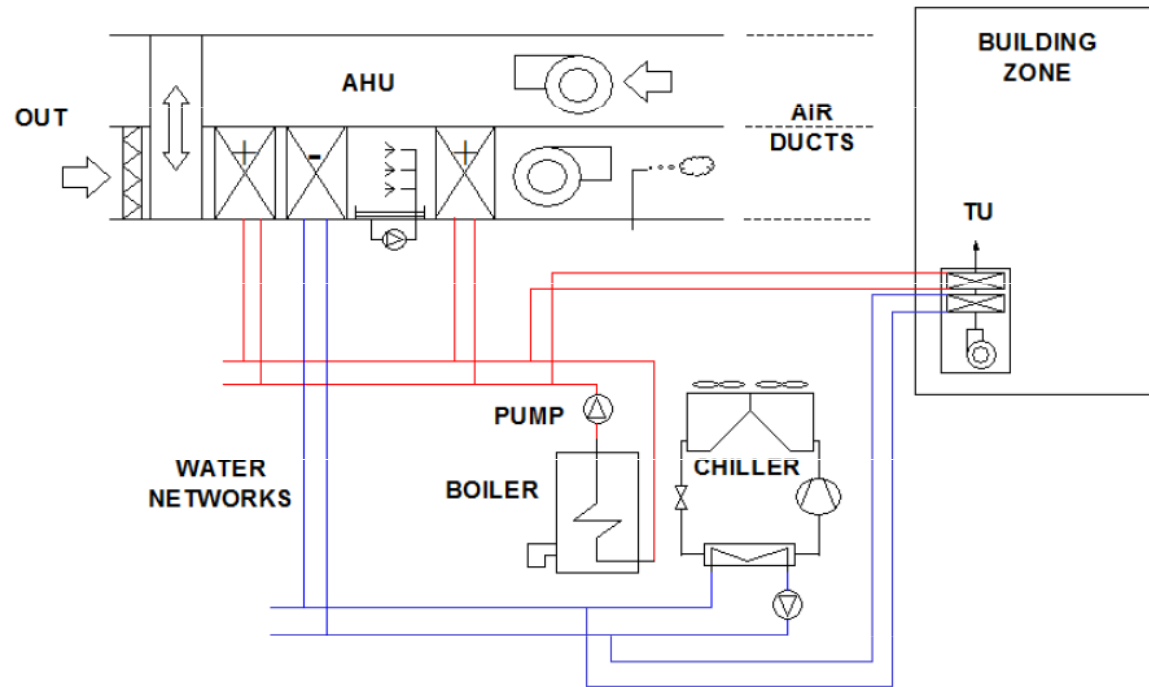

*(proportional control)*

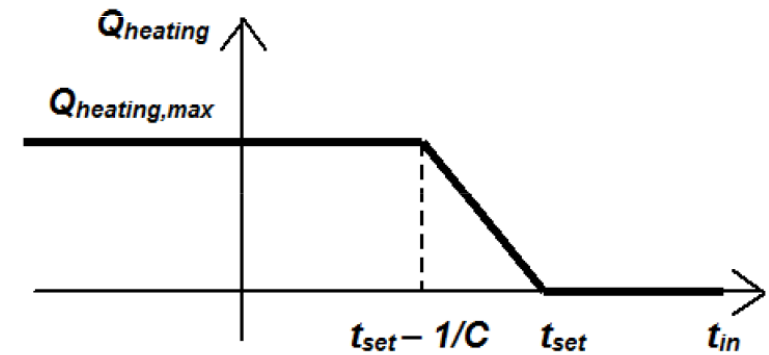

$$X_{\text{control}} = \text{MIN} (1, \text{MAX} (0, C_{\text{control}} * (t_{\text{sepoint}} - t)))$$

---

# Implementation in an Equation Solver

- Full transparency of the model :  
Software, User guide and model description are included : 3 in 1
- Easy continuous improvement and development of the software (adding of new HVAC components, ...)
- Well adapted to create and use simplified models using limited quantity of parameters and to solve differential equations
- Longer computation time than other softwares  
(about 20 minutes for a 8760 hours simulation of a building and its HVAC system)
- Convergence problems may be encountered when using too strict control laws

# Commercial Building Auditing Tool

- Application to a fictitious building, representative of the french building stock (IEA ECBCS Annex 48)
  - 15000 m<sup>2</sup> (12 storeys)
  - CAV system + FCU
  - offices and meeting rooms
- Comparison between simplified monozone tool (EES) and detailed multi zone tool (TRNSYS)

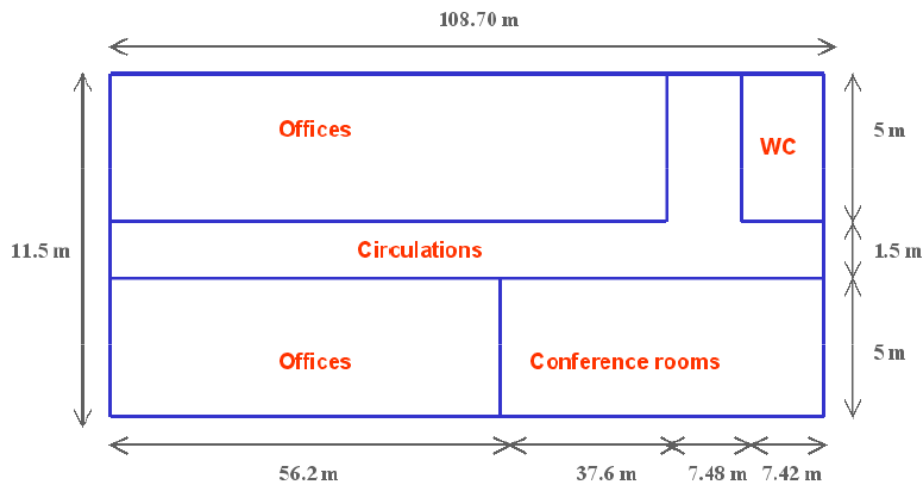

	Heating kWh/m <sup>2</sup>	Cooling kWh/m <sup>2</sup>
EES – mono-zone	53.7	32.8
TRNSYS - multi-zone	50.5	29.3
Relative Error - %	6.3 %	12 %

*(Sensible building demands;  
ideal local heating/cooling system)*

# Commercial Building Auditing Tool

- Fuel Consumption

Trnsys	EES
60.8 kWh/m <sup>2</sup> /yr	63.7 kWh/m <sup>2</sup> /yr

- System electricity demands

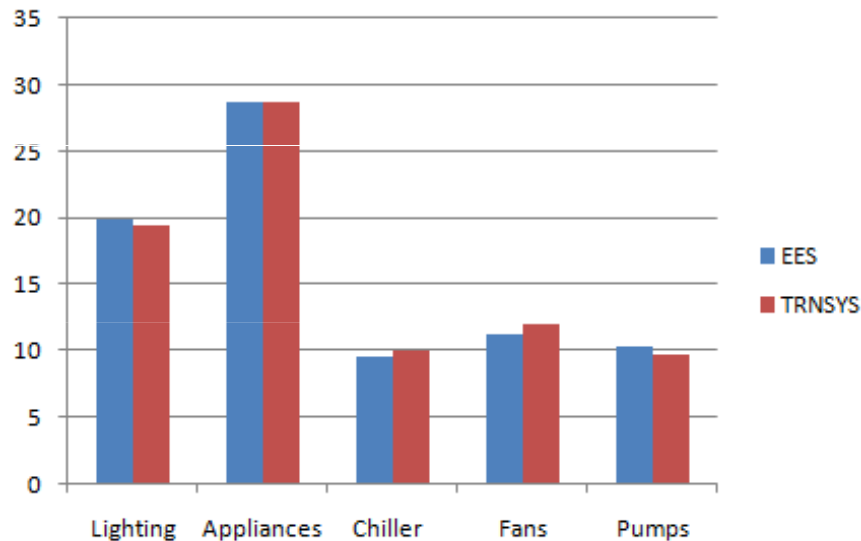

*(Electricity consumption, in kWh/m<sup>2</sup>/yr)*

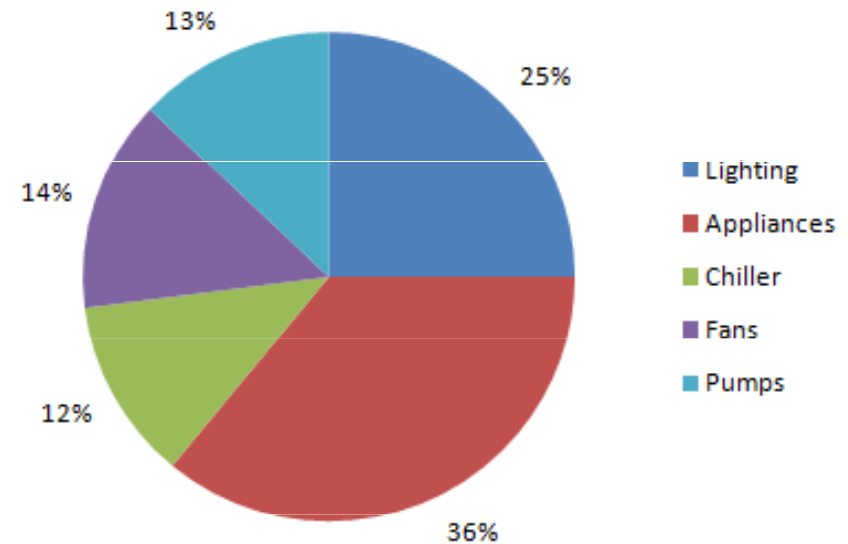

*(Electricity consumption distribution)*

---

# Table of Contents

- Introduction
- Building energy simulation tool for Audit
- Modelling Bases
- Validation of the building model
- Implementation in an equation solver and application
- **Conclusion**

---

# Conclusion

- Simplified lumped building model
  - Limited quantity of parameters
  - used with a “walls compositions library”
- Building zone model coupled to a complete HVAC system model
- Simulation tool implemented in an **Equation Solver**
  - Equation solver well adapted to the use of simplified models
  - Simplified lumped building model → **Eq. Solver well adapted to solve differential equations**
  - Simplified HVAC components models → **easily connected in Eq. Solver to run complete HVAC system simulation**
- Different versions of the tool are available at [www.labohtap.ulg.ac.be](http://www.labohtap.ulg.ac.be)

---

Thank you for your attention